

AMADEO®

FINGERS IN MOTION



PART OF THE
TYROSOLUTION

FACTS AND EXERCISES FOR DOCTORS, THERAPISTS AND PATIENTS.



tyromotion

AMADEO®

THERAPY WITH FINGERS, HAND AND BRAIN

AMADEO® may be used in all phases of finger-hand rehabilitation. **AMADEO®** can be adapted to the needs of every patient. Small and large hands. All fingers or only specific fingers. For neurological, orthopaedic and paediatric applications.

The therapeutic potential of neuronal plasticity in cases of neurological impairments is undisputed. Theories of cortical reorganization after brain lesion recommend early, intensive, repetitive and contextual training as an ideal strategy to facilitate relearning of motor function and to minimize motor deficit. (Mehrholz et al., 2012). Finger movement have been shown to stimulate the brain, thereby promoting neuroplasticity or regeneration of synapses (Pinter et al., 2013).

AMADEO® may be used with patients being treated for spasticity. By establishing force limits, speed and range of motion, the device always offers support in just the right intensity for the patient to work near the limit of their capacity.

AMADEO® can adapt to each patient individually because the following can be adjusted: the height of the table (through a hydraulic mechanism), the position of the hand unit in pronation and supination, and the spread of the finger movement.

PART OF THE
TYROSOLUTION



NEW APPROACHES TO THERAPY



AMADEO®, the patented end-effector system, enables intensive training with frequently repeated gripping movements that especially promote the learning process. Depending on the rehabilitation phase, the therapist has the option of selecting from between passive, assistive and active modes.

After attaching the fingers and thumb to the device, the therapist selects a customizable therapy program where the therapist can choose between interactive assessments and therapies. This facilitates the active exercise of finger strength, finger movement, movement control and a selective activation of the fingers.

AMADEO® supports the resolution of spasticity as well as the testing of tactile sensibility using therapy programs which are precisely geared to that purpose. Even without muscular strength, active work can be done using EMG-based training.

The Continuous Passive Motion (CPM Plus) therapy facilitates the implementation of automatic movement sequences even when the patient is unable to complete the entire range of motion on their own. The integration of a video with CPM Plus can be used for motivational purposes.

AMADEO® IN BRIEF

1. Robotics and sensor-based rehabilitation devices for use with either hand
2. Assistive and interactive therapies for individual fingers and thumbs movements
3. Patients can be set-up quickly and easily
4. Arm supports can be changed quickly
5. Can be used by adults and children in all rehabilitation phases
6. Can be used by patients with spasticity, or those with high tone
7. Objective assessments and reports
8. 4 assessment programs (strength, ROM, tone, spasticity)
9. Sensation and individual movement therapy
10. CPM Plus, EMG, spasticity treatment



DIMENSIONS

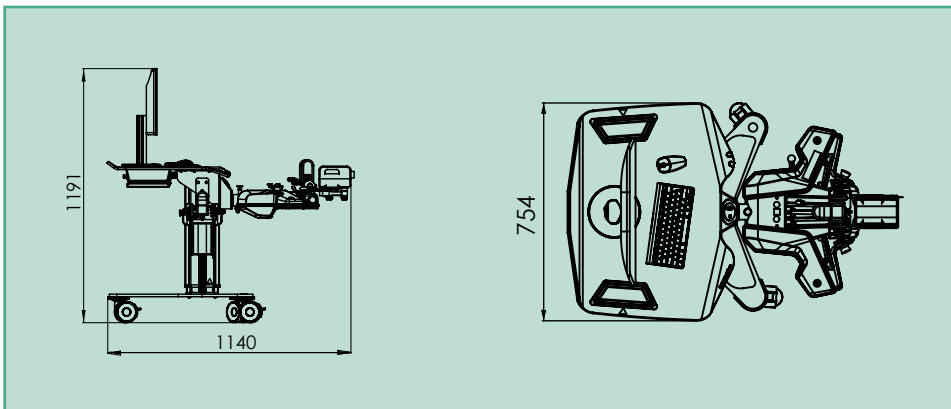

SOFTWARE TYROS

The integrated sensor system for each finger allows a quantitative recording, which provides real-time biofeedback and the evaluation of occurring active finger strengths and the active and passive ROM. The therapy progress assessed continuously, and is visible for the patients. Patient data and measurements are documented and may be exported. Additionally, **TYROS** can be connected to a server, making it possible to access the patient data from other departments. Since the data is stored in the **TYROS** database, this also facilitates the access to all other TYROSOLUTION devices. There is also an input and output interface to use raw data for scientific purposes.

ADJUSTABILITY

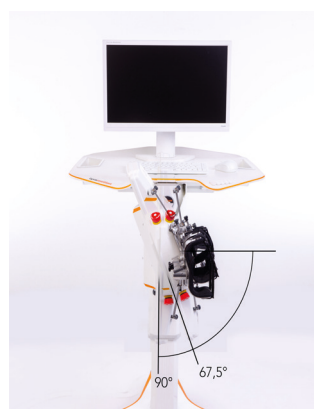
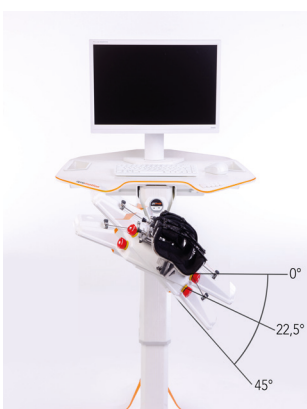

THERAPY APPLICATIONS

Children	✓
Adults	✓
Neurology	✓
Orthopaedics	✓
Strength measurement	✓
Tone measurement	✓
Range of movement measurement	✓
Spasticity measurement	✓
1D therapies (strength/ROM)	✓
2D therapies (strength/ROM)	✓
Continuous Passive Motion Plus	✓
Assistive therapy	✓
Spasticity treatment	✓
Sensation training	✓
EMG-triggered training	✓
Cognitive therapies developed in cooperation with Verena Schweizer	✓
Combination of strength/motor skills	✓
Suitable for both hands	✓
Robotics and computer-supported therapy device	✓
End-effector system	✓
Scientific I/O interfaces	✓
Table height adjustment	✓
Adjustable hand and arm support	✓
Adjustable for hand size or finger spread	✓
Incline adjustment mechanism (pronation and supination)	✓
Class IIa medical devices (CE- and FDA-approved)	✓
Scientific, educational and professional qualifications	✓

AMADEO® IN PRACTICE

RANGE OF MOTION ASSESSMENT

Provides a comparison of the patient's active and passive ROM for individual fingers and the thumb for either hand.

FORCE ASSESSMENT

The force assessment measures the patient's isometric finger and thumb strength for opening and closing of the hand and can be used to check therapy progress.

SPASTICITY ASSESSMENT & SPASTICITY TREATMENT

During the spasticity assessment, each digit is moved through their available ROM at 3 speeds, which allows a spasticity evaluation according to the Modified Ashworth Scale (MAS) and Modified Tardieu Scale (MTS). Based on the evaluation, the patient's treatment can be individualized for each patient.

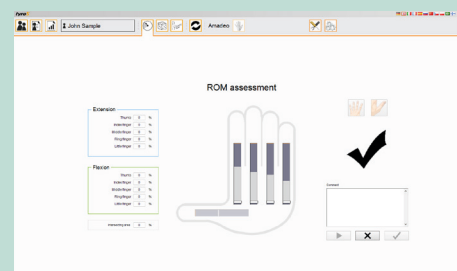

MOVEMENT THERAPIES - CPM PLUS

CPM therapy (Continuous Passive Motion) can be performed with this type of therapy. The therapist can select several criteria for the session including: movement speed, strength limit, wait time between movements, movement type (thumb and finger movements can be concurrent or alternating) and the time offset between digits can be configured.

SENSITIVITY TRAINING

This targets the haptic sensitivity of individual fingers. The therapist can individually adjust the position of the fingers, intensity of vibration as well as the frequency.

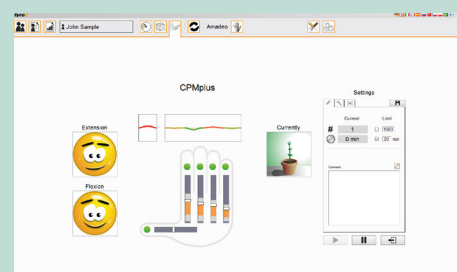

ASSISTIVE THERAPY

This program measures the patient's active ROM in flexion and extension. Once the patient has initiated as much movement as they are able, Amadeo® will assist as needed until the desired ROM is achieved.

THERAPIES - SERIOUS GAMING IN 1 & 2 DIMENSIONAL MOVEMENTS

Serious gaming actively involves the patient. The therapy software tyroS offers individual adjustability of the gaming parameters, monitoring of patient movements, feedback, documentation and the use on various tyromotion therapy devices. (1D accuracy, 1D reaction, 2D motor function, 2D cognition)

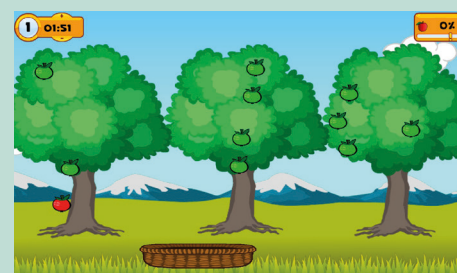

SURFACE ELECTROMYOGRAPHY (sEMG) TRAINING - ENABLES ACTIVE TRAINING, EVEN FOR PATIENTS WITHOUT MUSCULAR STRENGTH

sEMG can be detected during voluntary contractions in severely affected patients with very little to no function in their fingers and hand. The sEMG in combination with TyroS can increase patient initiated participation for patients without voluntary finger force or movement.



Sources and references: Mehrholz J., Hädrich A., Platz T., Kugler J., Pohl M. (2012) Electromechanical and robot-assisted arm training for improving generic activities of daily living, arm function, and arm muscle strength after stroke. The Cochrane Library, 2012

Pinter D., Pegritz S., Pargfrieder C., Reiter G., Wurm W., Gattringer T., Linderl-Madrutter R., Neuper C., Fazekas F., Grieshofer P., Enzinger C. (2013). Exploratory Study on the Effects of a Robotic Hand Rehabilitation Device on Changes in Grip Strength and Brain Activity after Stroke. Topic in Stroke Rehabilitation 20(4), 308-316