

MYRO[®]

MULTISENSORY THERAPY SYSTEM



PART OF THE
TYROSOLUTION

FACTS AND EXERCISES FOR DOCTORS, THERAPISTS AND PATIENTS.



tyromotion

MYRO®

INCREDIBLY VERSATILE

MYRO® is an interactive therapy system, which can be used in a multitude of ways: The sensor-based surface enables a task-oriented rehabilitation with real objects, trains the patient's abilities and improves motor abilities of the upper extremity. The force detection can be used with pressure and pull to assess, control therapy applications and enhance uni- or bilateral force control training. The large screen can optimally be used for spatially-explorative and cognitive training, visual motor integration skills training and specific exercises to improve the ROM.

PART OF THE
TYROSOLUTION



THERAPY POSSIBILITIES

The intended use of **MYRO®** is computer-assisted motoric and cognitive therapy for upper extremity. The **MYRO®** interactive therapy table is typically used in occupational therapy and physical therapy. In addition to conventional therapy **MYRO®** is used to assist, enhance, and intensify therapy in a motivational way. Repetitive and task-oriented movements of the upper extremity offers intrinsic and extrinsic stimuli to promote brain reorganization. Bilateral

work enables a better rewiring of the hemispheres. Repeated activity and training triggers neuroplasticity which modifies the central nervous system to recover functionality. For this reason, **MYRO®** in combination with tyroS Software offers assessment and therapy modules for individual therapy, which supports the principles of motor learning. The user is always supported by a multisensory feedback.

NEW THERAPY APPROACH

MYRO® focuses on an interactive handling with real objects, force control and touch applications. The benefit of using and combining those three control modes is the link to the activities of daily living. This link can be seen in push and pull force applications and in movement control with and without real objects. In detail, this movement control can be grouped for example in gross-motor skills, fine-motor-skills, rotation movement, hand-eye coordination, and motoric coordination applications. **MYRO®** can be used in individual therapy or group therapy.



"Diversity in the use and a wide range of different applications enables a goal- and task-oriented training in therapy for young and old!"

Amy Mayers, Occupational Therapist

MYRO® IN BRIEF

1. MYRO® is highly adaptable and provides with a working space for more than one person
2. Unilateral- and bilateral training
3. The device offers the possibility to use in combination with DIEGO
4. MYRO® offers full documentation and tracking of the therapy units



DIMENSIONS

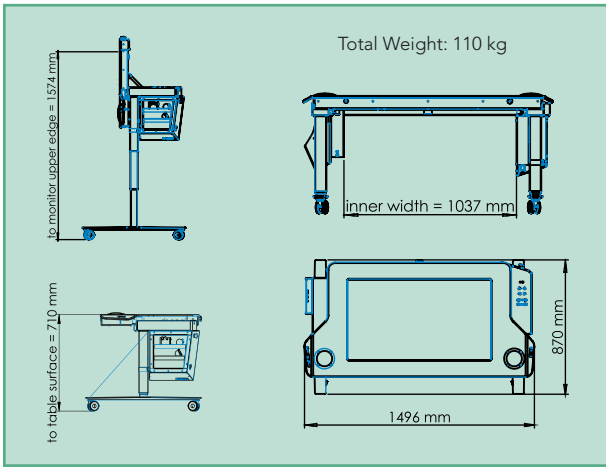

THERAPY WITH MYRO® VARIED AND VERSATILE.

The **MYRO®** interactive therapy table is mainly used in neurologic rehabilitation of the upper extremity. The target population includes not only neurologic but also orthopedic and pediatric patients with cognitive and motoric disorders. The large, adaptable screen in combination with the tyroS software offers a wide range of therapy options with different categories of therapy applications. This categories addresses for example people with deficits in motor function, concentration, selective attention, visual-spatial perception, and spatial-perceptive ability.

FEATURES

MYRO® provides an adaptable workspace, which includes height adjustment and tilting the table top. The changes of the screen size supports cognitive training and visual exploration. The sensors detect objects, which are part of the system, for movement applications and rotation, push and pull force and single point touch applications. The integrated tyroS Software contains assessments, therapy in different planes, pre-writing therapy, gross and fine motor skills exercises and cognitive therapy and progress over time can be seen as a feedback. Therapy can be executed in an individual single player or multiplayer mode.

ADJUSTABILITY

MYRO® can be adopted for different starting positions. This ensures a maximum of flexibility in application. The device can be used for sitting, standing, wheelchairs, or in post acute therapy in beds:

One of the center pieces of **MYRO®** is the versatile **TYROS** software. The device offers a variety of therapies and assessments:

THERAPY APPLICATIONS

Assessments	✓
Assistive Therapy	
One Plane of Movement	✓
Virtual Reality	
Robotic Aided Therapy	
Force	✓
Motor Function	✓
Force/motor Function	✓
Cognitive	✓
Proprioceptive	✓
Visual Motor Skills	✓



1. Starting Position



2. Extended for eg. wheelchair



3. Extended and tilted eg. standing



4. Fully tilted eg. hospital bed

MYRO® IN PRACTICE

1. SHAPE RECOGNITION AND REPRODUCTION

Reproduction of specific shapes can be used to improve and assess patients eye-hand coordination, concentration and ability to recognize abstract forms.



2. DAILY PLANNING

Scheduling a day is an essential part of our life. Daily routine and variety is important, especially for older people. In this application the therapist can work together with the patient on timing of daily events or on remembering and recalling things that already happened.



3. VISUAL EXPLORATION

Patients with neglect often show an impaired ability according to their binocular vision. With special settings in our **TYROS** software we can individualize the task to the patient's needs in order to improve their focus on the affected side.



4. THINK BEFORE YOU ACT

The intended use of **MYRO**® is computer-assisted motoric and cognitive therapy for upper extremity. The **MYRO**® interactive therapy table is typically used in occupational therapy and physical therapy. In addition to conventional therapy **MYRO**®



5. ENHANCE EYE-HAND COORDINATION AND CONCENTRATION ASSETS

Different templates (e.g. mirrored cat / grid) to work on eye-hand coordination, concentration, accuracy and creativity.

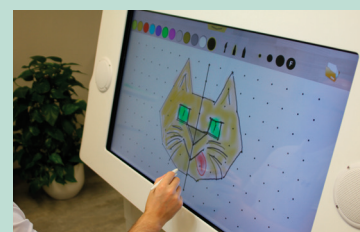

6. ASSISTIVE MOVEMENT THERAPY

In combination with **DIEGO** a therapy for severely affected patients is possible. The **IGC** (Intelligent Gravity Compensation) can help the patient to execute movements without compensation modes. A perfect combination and help to make therapy effective and possible for everyone. With the use of a **MYRO**®-object no fine-motor skills are needed to perform the task.



7. BE CREATIVE – YOUR SURFACE TO EXPRESS YOURSELF

Serious gaming actively involves the patient. The therapy software **tyroS** offers individual adjustability of the gaming parameters, monitoring of patient movements, feedback, documentation and the use on various **tyromotion** therapy devices. (1D accuracy, 1D reaction, 2D motor function, 2D cognition)



Sources and references: Mehrholz J., Hädrich A., Platz T., Kugler J., Pohl M. (2012) Electromechanical and robot-assisted arm training for improving generic activities of daily living, arm function, and arm muscle strength after stroke. The Cochrane Library, 2012

Pinter D., Pegritz S., Pargfrieder C., Reiter G., Wurm W., Gattringer T., Linderl-Madrutter R., Neuper C., Fazekas F., Grieshofer P., Enzinger C. (2013). Exploratory Study on the Effects of a Robotic Hand Rehabilitation Device on Changes in Grip Strength and Brain Activity after Stroke. *Topic in Stroke Rehabilitation* 20(4), 308-316